

BHD94GU

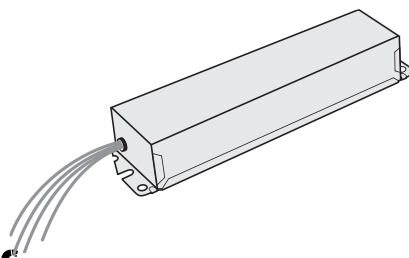

bodine

Universal Input Installation Instructions

EMERGENCY LIGHTING EQUIPMENT



! IMPORTANT SAFEGUARDS !

WHEN USING ELECTRICAL EQUIPMENT, BASIC SAFETY PRECAUTIONS SHOULD ALWAYS BE FOLLOWED, INCLUDING THE FOLLOWING:

READ AND FOLLOW ALL SAFETY INSTRUCTIONS

1. To prevent high voltage from being present on red, yellow & yellow/black output leads prior to installation, inverter connector must be open. Do not join inverter connector until installation is complete and AC power is supplied to the emergency ballast.
2. This product is for use with one 18 W through 42 W (4-pin) compact fluorescent lamp without integral starter.
3. Make sure all connections are in accordance with the National Electrical Code or Canadian Electrical Code and any local regulations.
4. To reduce the risk of electric shock, disconnect both normal and emergency power supplies and inverter connector of the emergency ballast before servicing.
5. This emergency ballast is for factory installation only.
6. This product is suitable for damp locations where the ambient temperature for fixture is 0°C minimum, +50°C maximum. This product is suitable for use in sealed and gasketed fixtures.
7. An unswitched AC power source is required (120 through 277 VAC, 50 or 60 Hz).
8. Do not install near gas or electric heaters.
9. Do not attempt to service the battery. A sealed, no-maintenance battery is used that is not field replaceable. Contact the manufacturer for information on service.
10. The use of accessory equipment not recommended by the manufacturer may cause an unsafe condition.
11. Do not use this product for other than intended use.
12. Servicing should be performed by qualified service personnel.

CAUTION: Verify that all replacement lamp types marked on the installed luminaire are also identified as suitable for use with this inverter/charger pack.

SAVE THESE INSTRUCTIONS

THIS COMPONENT IS INCOMPLETE IN CERTAIN CONSTRUCTION FEATURES OR RESTRICTED IN PERFORMANCE CAPABILITIES AND NOT INTENDED FOR SEPARATE INSTALLATION IN THE FIELD; RATHER IT IS INTENDED FOR USE AS A COMPONENT OF COMPLETE EQUIPMENT SUBMITTED FOR INVESTIGATION BY UNDERWRITERS LABORATORIES INC. FINAL ACCEPTANCE OF THE COMPONENT IN THE COMPLETE EQUIPMENT IS DEPENDENT UPON ITS INSTALLATION AND USE IN ACCORDANCE WITH ALL APPLICABLE USE CONDITIONS AND RATINGS NOTED IN THE COMPONENT REPORT ISSUED BY UNDERWRITERS LABORATORIES INC.



**THIS PRODUCT CONTAINS A RECHARGEABLE NICKEL-CADMIUM BATTERY.
THE BATTERY MUST BE RECYCLED OR DISPOSED OF PROPERLY.**

Ni - Cd

01/08/19

Bodine © 2018 Signify Holding. All rights reserved.

236 Mt. Pleasant Rd. • Collierville, TN USA 38017-2752 • Tech Support 888-263-4638 • Fax 901-853-5009 • www.bodine.com
81000075

INSTALLATION

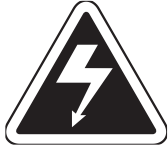

WARNING: TO PREVENT HIGH VOLTAGE FROM BEING PRESENT ON RED, YELLOW & YELLOW/BLACK OUTPUT LEADS PRIOR TO INSTALLATION, INVERTER CONNECTOR MUST BE OPEN. DO NOT JOIN INVERTER CONNECTOR UNTIL INSTALLATION IS COMPLETE AND AC POWER IS SUPPLIED TO THE EMERGENCY BALLAST.

NOTE: Make sure the necessary branch circuit wiring is available. An unswitched source of power is required. The emergency ballast must be fed from the same branch circuit as the AC ballast.

STEP #1 INSTALLING THE EMERGENCY BALLAST

- > Disconnect AC power from the fixture.
- > Make electrical connections in accordance with the National Electrical Code or Canadian Electrical Code and any local regulations. If provisions for remote installation are provided by the luminaire manufacturer, the emergency ballast may be installed up to half the distance the AC ballast manufacturer recommends removing the AC ballast from the lamp, or up to 10 feet, whichever is less. If no AC ballast is used, the emergency ballast can be remotely mounted up to 10 feet away.
- > **Mounting Height:** This product meets or exceeds the NFPA minimum light requirements with all loads, down to the smallest rated lamp load, at heights up to 7.17ft (2.2m). Many factors influence emergency illumination levels, such as the lamp load selected, luminaire design, and environmental factors therefore end use verification is necessary. For field installations, when the attached luminaire is mounted at heights greater than 7.17ft (2.2m), the level of illumination must be measured in the end application to ensure the requirements of NFPA 101 and local codes are satisfied.
- > Depending on the type of fixture in use, install emergency ballast using one of the methods illustrated below.
- > On switched fixtures, an additional unswitched hot wire (120 through 277 VAC, 50/60 Hz) must be run and connected to the emergency ballast.

STEP #2 WIRING THE EMERGENCY BALLAST

- > Cut the fixture wires between the lamp holder and AC ballasts and connect the blue and blue/white emergency ballast wires to the AC ballast and the yellow and yellow/black wires to the lamp holder.
- > Connect the LED by matching violet and brown leads.
- > After installation is complete, supply AC power to the emergency ballast and join the inverter connector.

STEP #3 EMERGENCY BALLAST QUICK CHECK AND LABELING

- > For short-term testing of the emergency function, the battery must be charged for at least one hour. The emergency ballast must be charged for at least 24 hours before conducting a long-term test.
- > In a readily visible location, attach the label "CAUTION: This Unit Has More Than One Power Supply Connection Point. To Reduce The Risk Of Electric Shock, Disconnect Both The Branch Circuit-Breakers Or Fuses And Emergency Power Supplies Before Servicing."

INSTALLATION

OPERATION

When AC power is applied, the charging indicator light is illuminated, indicating the battery is being charged. When power fails, the emergency ballast automatically switches to emergency power, operating one lamp at reduced illumination. When AC power is restored, the emergency ballast returns to the charging mode and delays AC ballast operation for approximately three seconds to prevent false-tripping of AC ballast (end-of-lamp-life) shutdown circuits. This emergency ballast will operate one 18W through 42W lamp for a minimum of 90 minutes.

MAINTENANCE

Although no routine maintenance is required to keep the emergency ballast functional, it should be checked periodically to ensure that it is working. The following schedule is recommended:

1. Visually inspect the charging indicator light monthly. It should be illuminated.
2. Test the emergency operation of the fixture at 30-day intervals for a minimum of 30 seconds. One lamp should operate at reduced illumination.
3. Conduct a 90-minute discharge test once a year. One lamp should operate at reduced illumination for at least 90 minutes.

! REFER ANY SERVICING INDICATED BY THESE CHECKS TO QUALIFIED PERSONNEL !

EMERGENCY BALLAST AND AC BALLAST MUST BE FED FROM THE SAME BRANCH CIRCUIT
TYPICAL SCHEMATICS ONLY. MAY BE USED WITH OTHER BALLASTS. CONSULT THE FACTORY FOR OTHER WIRING DIAGRAMS.

WIRING DIAGRAMS

ONE (1) 4-PIN COMPACT LAMP RAPID START BALLAST

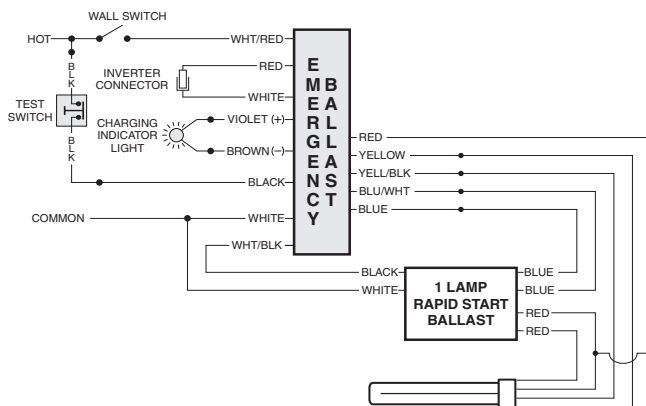

TWO (2) 4-PIN COMPACT LAMP RAPID START BALLAST

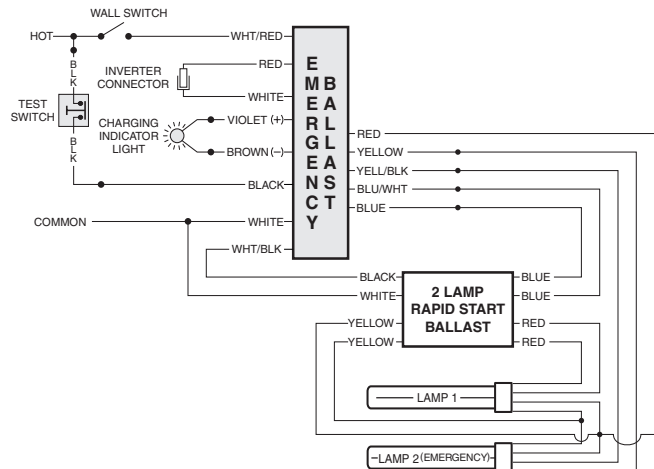

NOTE: For EMERGENCY-ONLY option, contact factory.